



5-ton Air-Cooled Chiller

Wide Ambient Range

A wide range of indoor-duty air-cooled, water-cooled, or remote air-cooled condensers as well as outdoor air-cooled chillers fit a variety of applications.

Easy Access Cabinet

Heavy-gauge machine access doors with industrial grade tools-free latches provide quick access to all components for easy operation and maintenance.

Compressor Protection Technology

Our compressor protection technology uses start-to-start anti-recycle control logic to limit cycling under low-load operating conditions to extend compressor life.

Compressor and Pump Run Hour Displays

The ability to monitor compressor and pump running hours is useful and is an important tool to assist with scheduling maintenance.

Power Monitor

The main power monitoring system protects the chiller from extensive damage to the compressor and pump due to loss of phase or phase reversal in the main supply.

Standard Features

Direct Drive Scroll Compressors

Direct drive hermetically sealed scroll compressors with proven performance in industrial cooling for reliable, low maintenance, and efficient operation.

Stainless Steel Evaporators

High-efficiency stainless steel plates with copper brazing provide maximum performance, long life, and enhanced level of protection from harsh process conditions.

Stainless Steel Pump

Stainless steel pump selected for peak performance with the utmost in corrosion protection to ensure a long useful life under severe industrial conditions.

Nonferrous Reservoir and Water Lines

The insulated reservoir, fluid lines, pumps, and other components in the process fluid circuit will remain free of rust to provide maximum corrosion protection.

Evaporator Inlet Strainer

The evaporator inlet strainer removes any debris present in the process fluid to prevent costly downtime and repair due to a clogged chiller evaporator.

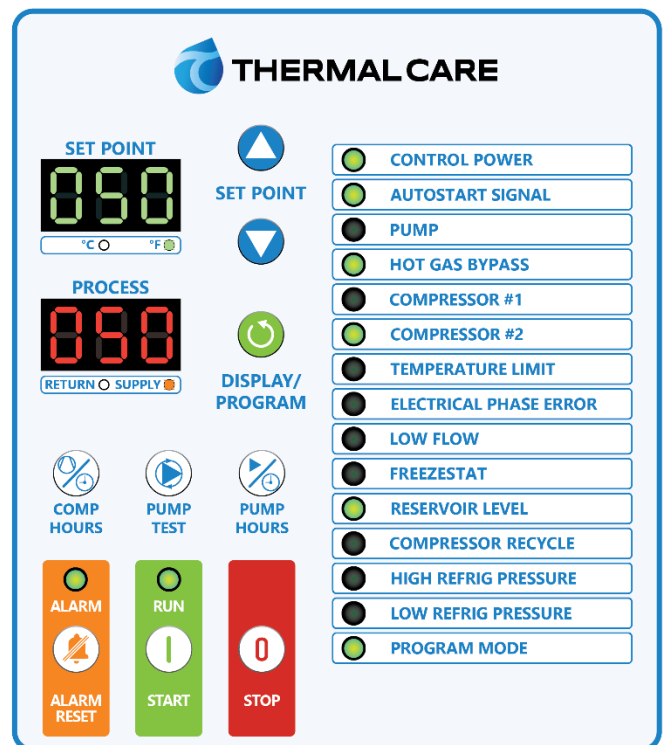

Standard Controller

Accuchiller NQ Portable Chiller

Temperature Deviation Warnings and Alarms

A warning alerts the operator of a potential problem before a fault occurs and if the condition gets worse, an alarm stops the chiller to prevent damage.

Adjustable Deviation Alarm Time Delays

Allows for programming a start-up alarm time delay to deactivate the alarms long enough for the process loop to stabilize before activating the alarms.

Reservoir Low Level Alarm

Indicates a low process fluid condition and protects the process pump and chiller from expensive damage caused by a critically low operating level in the reservoir.

Master Reset

The master reset function is a quick and easy way to reset and restore the control system to factory default settings if a control parameter is mistakenly changed.

Supply and Return Temperature Displays

The ability to view the process supply and return temperatures provides an additional tool for monitoring process conditions.

High-Quality 24 VDC Power Supply

The 24-volt DC power supply ensures dependable control circuit power and isolates the control circuit from static interference to ensure stable and precise operation.

Other Alarms

All chillers include loss of flow, freestat, high and low refrigeration pressure, temperature sensor faults, and freestat sensor fault alarms.

Warranty

5 year parts on standard controller, lifetime \$175 exchange
 3 year parts on the optional premium PLC controller
 18 months parts on entire unit
 1 year labor

Variable-Speed Compressor Options

Chillers usually operate with process heat loads less than 100% of available chiller capacity. With increasing emphasis on energy efficiency, we offer a variable-speed scroll compressor option for improved part-load efficiency.

Most chillers use fixed-speed compressors with a hot gas bypass valve that bypasses hot discharge refrigerant gas back into the compressor to simulate 100% load. This keeps the compressor running at full speed all the time.

Our variable-speed scroll compressor technology varies the compressor speed to match the process load. This means the compressor slows down under part load conditions for peak performance and reduced power use.

10-Ton Variable-Speed Option Payback (Years)

Hours of Operation	Process Load (Percent of Full Capacity)								
	50%	55%	60%	65%	70%	75%	80%	85%	90%
4,000/year	1.1	1.2	1.3	1.4	1.6	1.8	2.3	3.0	4.7
6,000/year	0.7	0.8	0.8	0.9	1.0	1.2	1.5	2.0	3.2
8,400/year	0.5	0.5	0.6	0.7	0.7	0.9	1.1	1.4	2.3

Based on \$0.10/kWhr power cost

15-Ton Variable-Speed Option Payback (Years)

Hours of Operation	Process Load (Percent of Full Capacity)								
	50%	55%	60%	65%	70%	75%	80%	85%	90%
4,000/year	0.9	1.0	1.1	1.2	1.4	1.8	2.4	3.7	9.4
6,000/year	0.6	0.7	0.7	0.8	1.0	1.2	1.6	2.4	6.3
8,400/year	0.4	0.5	0.5	0.6	0.7	0.8	1.1	1.7	4.5

Based on \$0.10/kWhr power cost

20-Ton Variable-Speed Option Payback (Years)

Hours of Operation	Process Load (Percent of Full Capacity)								
	50%	55%	60%	65%	70%	75%	80%	85%	90%
4,000/year	1.1	1.1	1.1	1.1	1.1	1.3	1.6	2.2	3.7
6,000/year	0.7	0.7	0.7	0.7	0.7	0.9	1.1	1.4	2.4
8,400/year	0.5	0.5	0.5	0.5	0.5	0.6	0.8	1.0	1.7

Based on \$0.10/kWhr power cost

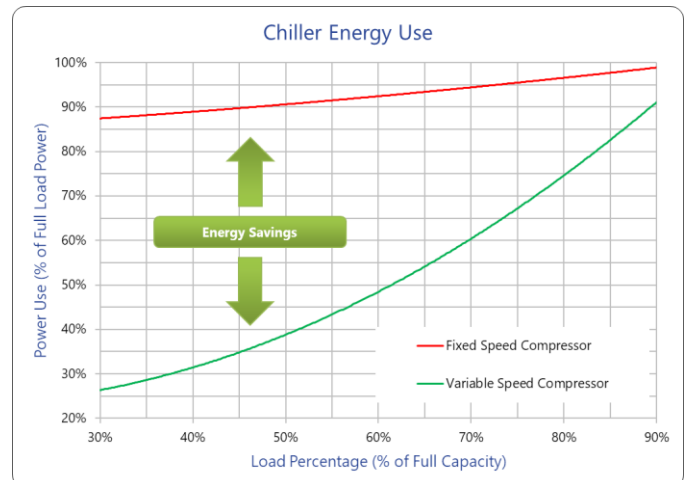

Accuchiller NQ Portable Chiller

PLC Option

Standard on units with the variable-speed option and available on all others is a PLC with 7-inch touch screen to provide an enhanced level of monitoring and control.

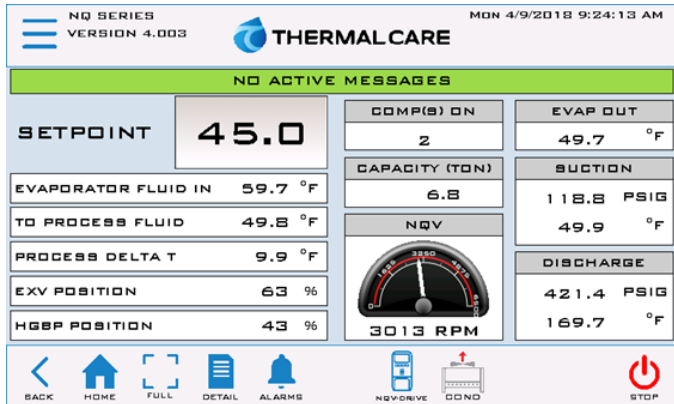

Sample of Home Screen (unit with variable-speed compressor option)

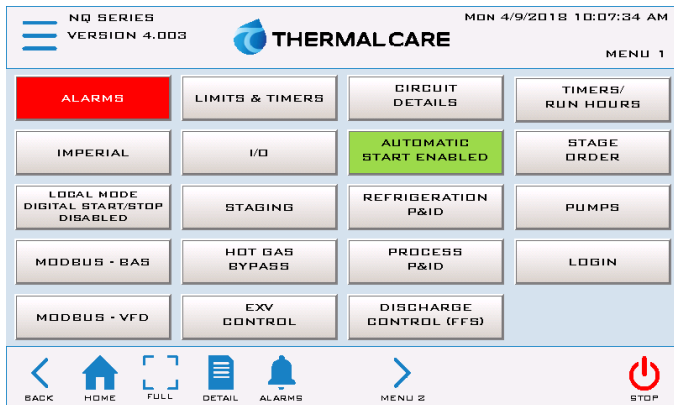

Sample of a Menu Screen

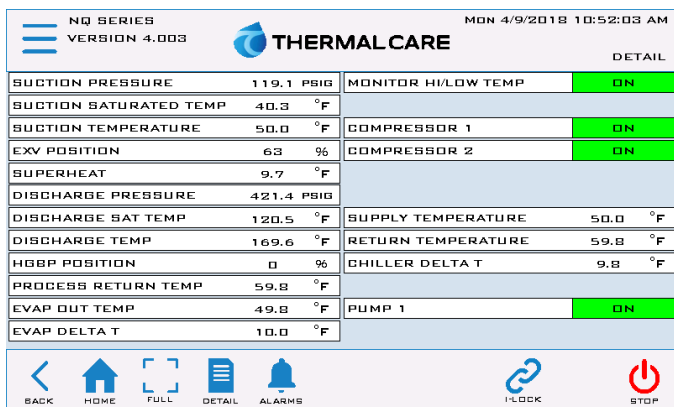

Sample of a Detail Screen

Other Available Options

- High flow / high pressure pumps
- High flow unit design
- Alarm horn
- Alarm relay
- Rotary non-fused or fused disconnect switch
- C-UL508A industrial control panel construction
- Outdoor-duty construction
- Extended condenser air range (0°F to 110°F)
- High temperature condenser air range (60°F to 122°F)
- Low temperature condenser air range (-20°F to 110°F)
- Wide temperature condenser air range (0°F to 122°F)
- Air-cooled condenser coil coating for coastal regions
- Pump and tank deduct
- Oversized reservoirs
- Water circuit designed for use with de-ionized water
- Stainless steel cabinetry
- Automatic electric water make-up valve
- High pressure fans for ducting of discharge air
- 4 to 20 mA cooling supply temperature retransmit
- Emergency stop button
- Hand-held remote controller with 50 foot wire
- Special color paint
- Modbus RTU, BACnet, LonWorks, or SPI communications

Accuchiller NQ Portable Chiller

Air-Cooled Condenser Chillers

Model	NQA04	NQA05	NQA08	NQA10	NQA13	NQA15	NQA20	NQA25	NQA30
Cooling Capacity (tons) ¹	4	5	8	11	13	15	21	26	31
Set Point Range (°F)	20 to 80	20 to 80	20 to 80	20 to 80	20 to 80	20 to 80	20 to 80	20 to 80	20 to 80
Compressor (qty)	1	1	1	1	1	1	2	2	2
Sound Pressure @ 1 meter (dBA)	74	74	76	76	76	82	84	84	86
Pump Motor Size (hp)	1.5	1.5	1.5	2	2	3	5	5	5
Pump Flow (gpm)	11	12	19	27	30	36	48	60	72
Net Available Pump Pressure (psi) ²	39	39	37	38	37	44	54	54	49
Reservoir Holding Capacity (gal)	11	11	22	22	22	40	50	67	67
Shipping Weight (lbs)	720	720	1,195	1,195	1,215	3,200	3,300	3,800	4,150
Operating Weight (lbs)	810	810	1,380	1,380	1,400	3,535	3,715	4,360	4,710
MCA @ 460/3/60 (amps) ³	16	18	26	31	37	44	58	70	83
MOP @ 460/3/60 (amps) ⁴	25	30	45	60	70	80	80	100	125

¹Cooling tons based on 12,000 BTU/Hr/ton with 50°F leaving coolant and 95°F ambient air, R410A refrigerant.

²Net available pressure at outlet of chiller is pump discharge pressure less the internal pressure loss through the fluid circuit.

³MCA is Minimum Circuit Amps with standard condenser fan(s) and pump under full load, used for minimum wire size requirement.

⁴MOP is Maximum Overcurrent Protection with standard condenser fans(s) and pump, used for sizing main power protection devices.

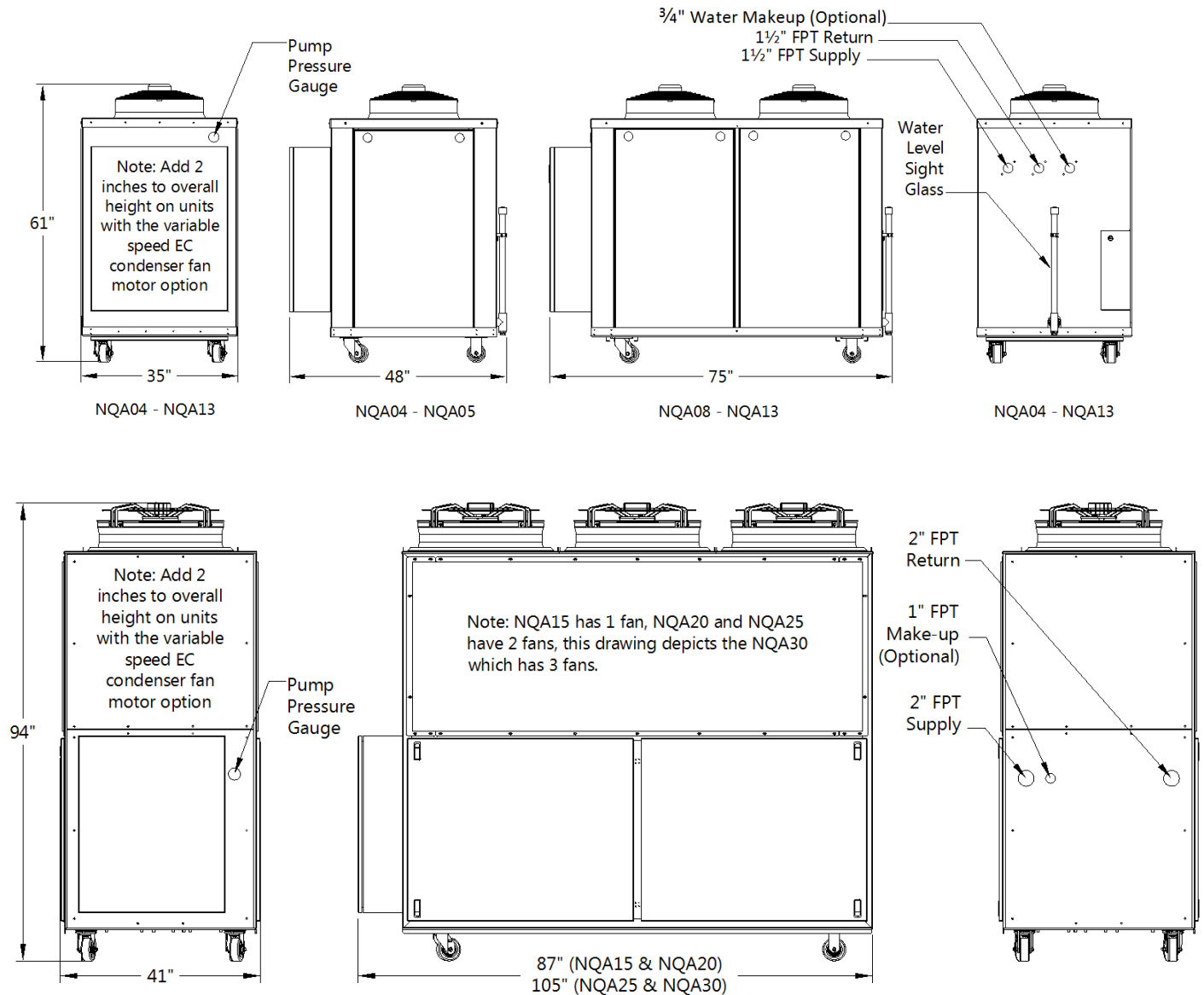

Accuchiller NQ Portable Chiller

Water-Cooled Condenser Chillers

Model	NQW05	NQW08	NQW10	NQW15	NQW20	NQW25	NQW30	NQW35	NQW40
Cooling Capacity (tons) ¹	6	8	12	17	23	28	33	38	43
Set Point Range (°F)	20 to 80	20 to 80	20 to 80	20 to 80	20 to 80	20 to 80	20 to 80	20 to 80	20 to 80
Compressor (qty)	1	1	1	1	2	2	2	2	2
Sound Pressure @ 1 meter (dBA)	70	70	71	73	74	74	75	77	78
Pump Motor Size (hp)	1.5	1.5	2	3	5	5	5	5	5
Pump Flow (gpm)	13	20	29	39	54	67	79	92	102
Net Available Pump Pressure (psi) ²	38	35	36	40	50	50	45	43	39
Reservoir Holding Capacity (gal)	11	22	22	22	50	50	67	67	67
Shipping Weight (lbs)	720	1,195	1,195	1,315	1,900	2,100	2,250	3,400	3,900
Operating Weight (lbs)	810	1,380	1,380	1,500	2,315	2,515	2,810	3,960	4,460
MCA @ 460/3/60 (amps) ³	16	23	28	40	49	61	69	74	78
MOP @ 460/3/60 (amps) ⁴	30	40	50	70	70	90	100	110	110

¹Cooling tons based on 12,000 BTU/Hr/ton with 50°F leaving coolant and 85°F condenser water, R410A refrigerant.

²Net available pressure at outlet of chiller is pump discharge pressure less the internal pressure loss through the fluid circuit.

³MCA is Minimum Circuit Amps with standard pump under full load, used for minimum wire size requirement.

⁴MOP is Maximum Overcurrent Protection with standard pump, used for sizing main power protection device.

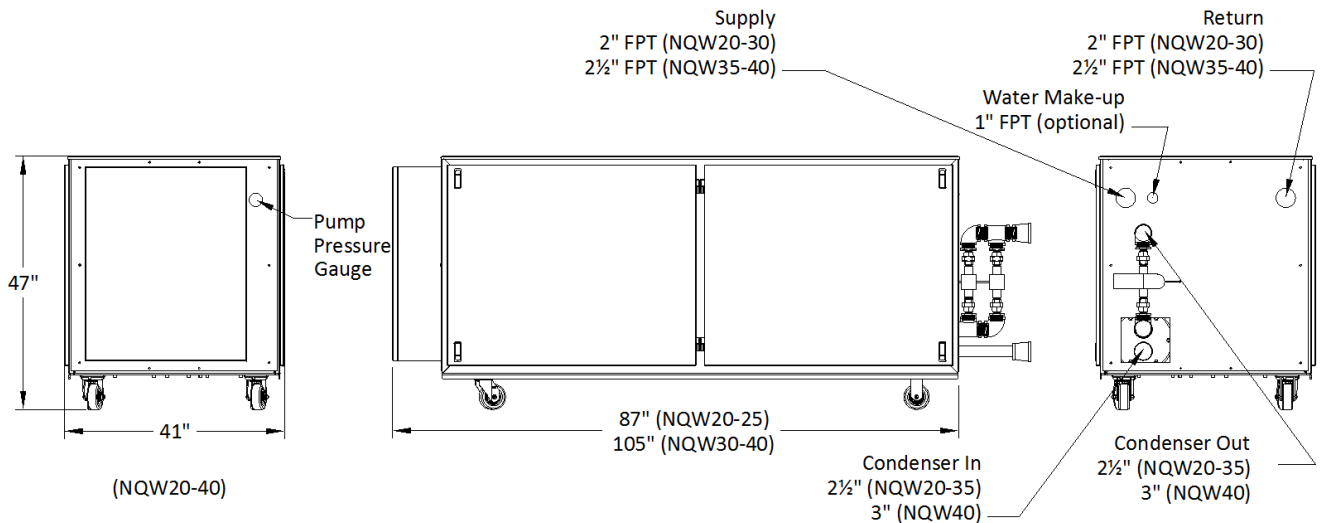
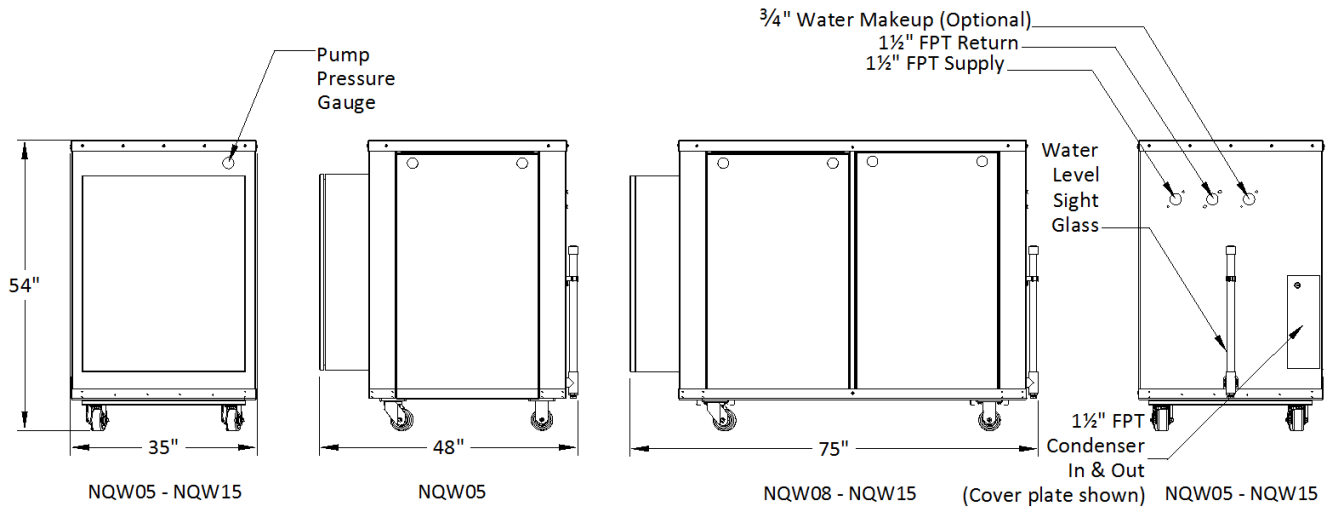

Accuchiller NQ Portable Chiller

Remote Air-Cooled Condenser Chillers

Model	NQR05	NQR08	NQR10	NQR15	NQR20	NQR25	NQR30	NQR35	NQR40
Cooling Capacity (tons) ¹	5	8	11	15	21	26	31	35	40
Set Point Range (°F)	20 to 80	20 to 80	20 to 80	20 to 80	20 to 80	20 to 80	20 to 80	20 to 80	20 to 80
Compressor (qty)	1	1	1	1	2	2	2	2	2
Sound Pressure @ 1 meter (dBA) ²	70	70	71	73	74	74	75	77	78
Pump Motor Size (hp)	1.5	1.5	2	3	5	5	5	5	5
Pump Flow (gpm)	13	18	27	36	50	61	73	83	92
Net Available Pump Pressure (psi) ³	38	38	38	44	53	53	49	47	44
Reservoir Holding Capacity (gal)	11	22	22	22	50	50	67	67	67
Shipping Weight (lbs)	720	1,195	1,195	1,315	1,900	2,100	2,250	3,400	3,900
Operating Weight (lbs)	810	1,380	1,380	1,500	2,315	2,515	2,810	3,960	4,460
MCA @ 460/3/60 (amps) ⁴	16	23	28	40	49	61	69	74	78
MOP @ 460/3/60 (amps) ⁵	30	40	50	70	70	90	100	110	110

¹Cooling tons based on 12,000 BTU/Hr/ton with 50°F leaving coolant and 95°F ambient air, R410A refrigerant.

²Sound pressure is for the chiller unit only. See the Remote Air-Cooled Condenser table for remote condenser sound pressures.

³Net available pressure at outlet of chiller is pump discharge pressure less the internal pressure loss through the fluid circuit.

⁴MCA is Minimum Circuit Amps with standard pump under full load, used for minimum wire size requirement.

⁵MOP is Maximum Overcurrent Protection with standard pump, used for sizing main power protection device.

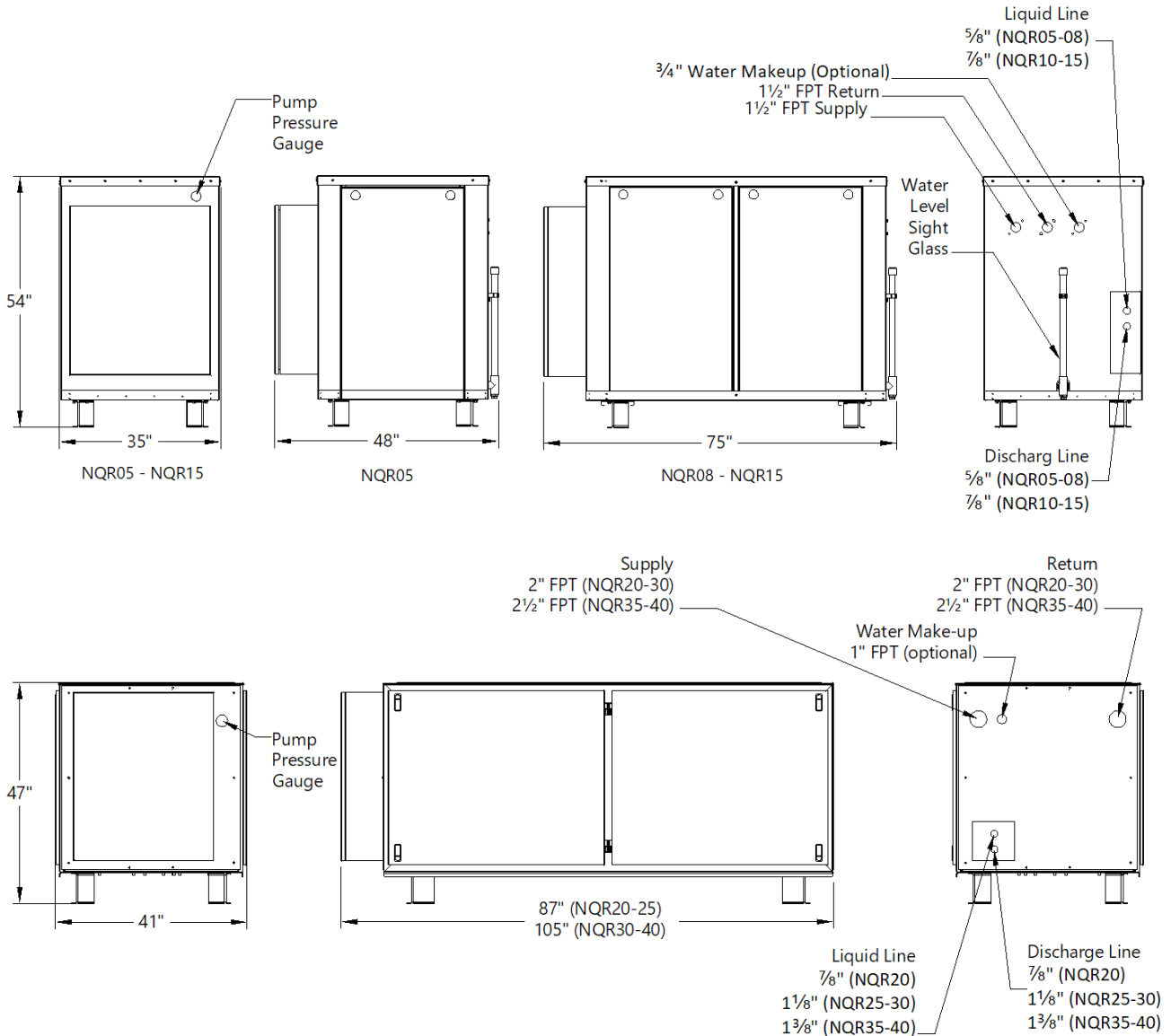

Accuchiller NQ Portable Chiller

Remote Air-Cooled Condensers

Condenser Model	KCM009	KCM011	KCM014	KCL023	KCL030	KCL037	KCL045	KCL054	KCL056
Chiller Used With	NQR05	NQR08	NQR10	NQR15	NQR20	NQR25	NQR30	NQR35	NQR40
Fans (qty)	1	1	2	2	2	2	3	3	3
Shipping Weight (lbs)	245	265	415	680	720	1,050	1,075	1,175	1,450
Operating Weight (lbs)	Varies based on system charge and operating conditions								
MCA @ 460/3/60 (amps) ²	1.4	1.4	2.6	7	7	7	10.1	10.1	10.1
MOP @ 460/3/60 (amps) ³	15	15	15	15	15	15	15	15	15

¹MCA is Minimum Circuit Amps, used for minimum wire size requirement.

²MOP is Maximum Overcurrent Protection, used for sizing main power protection device.

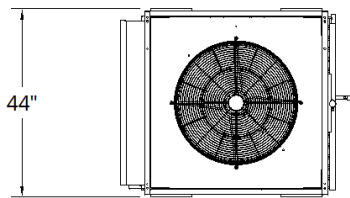

KCM009 used with Model NQR05 chiller
KCM011 used with Model NQR08 chiller

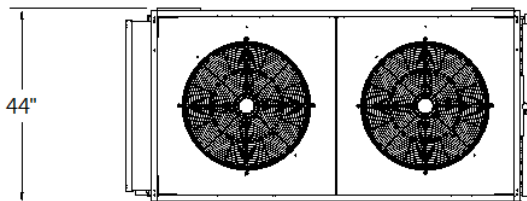
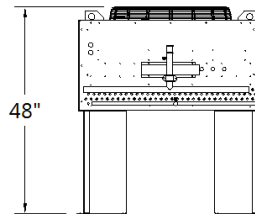
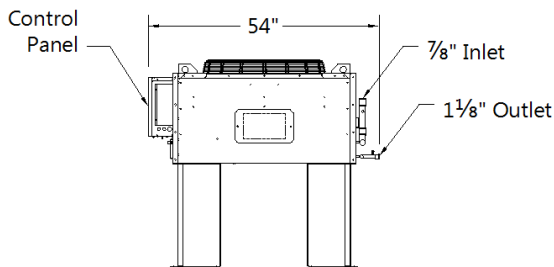

KCM014 used with Model NQR10 chiller

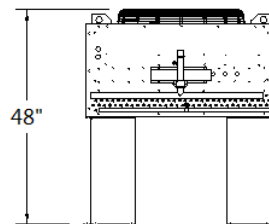
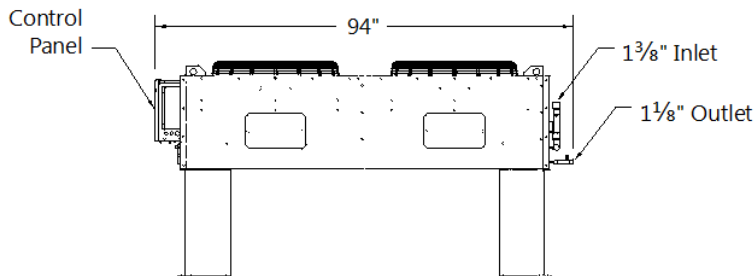

Accuchiller NQ Portable Chiller

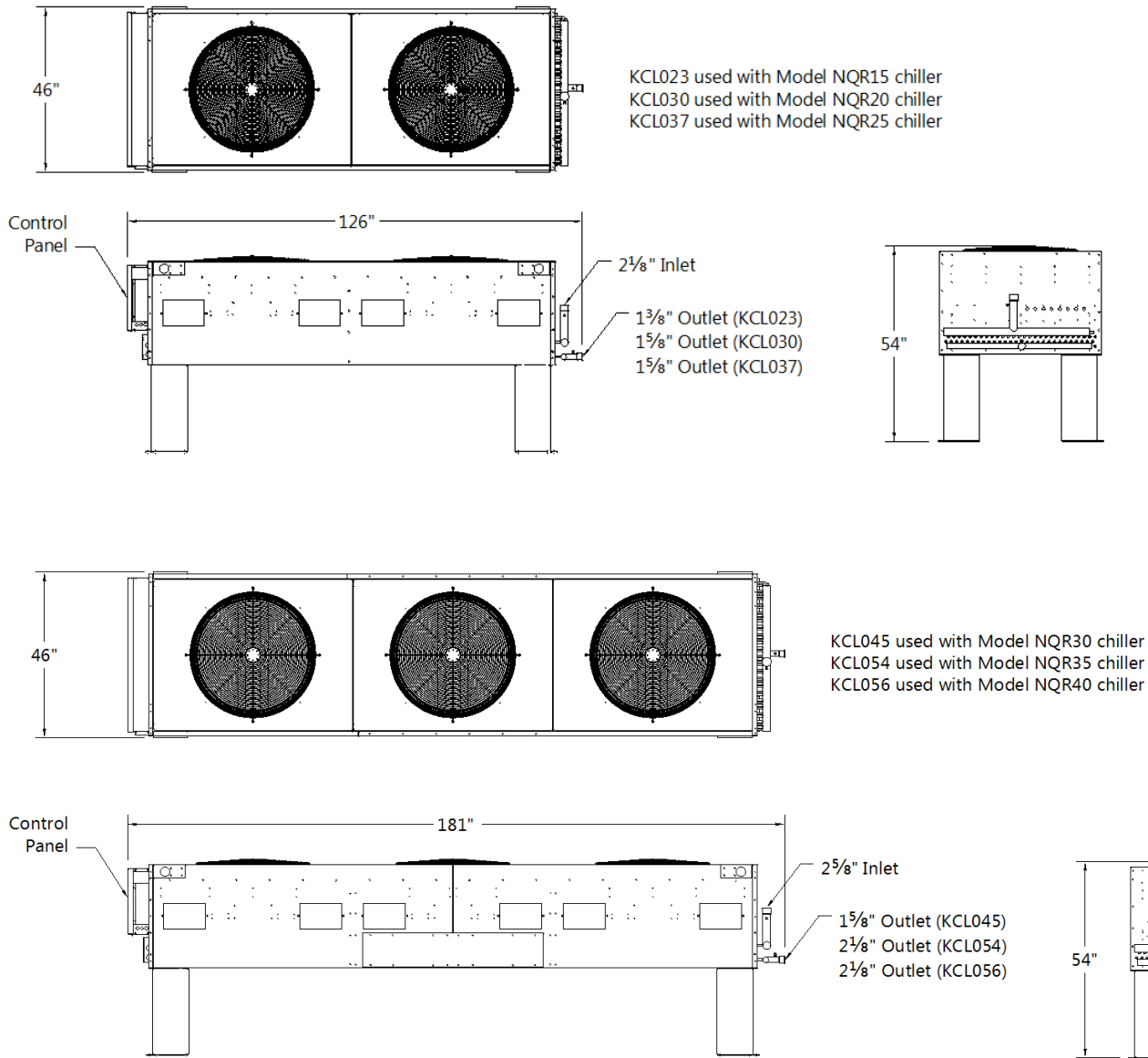

5680 W. Jarvis Ave • Niles, IL 60714
847-966-2260 • info@thermalcare.com
www.thermalcare.com

Thermal Care is ISO-9001 Certified
Manufacturer reserve the right to change specification
or design without notification or obligation
NQ Specification 01